

SODIUM CHLORIDE- sodium chloride injection, solution

Hospira, Inc.

SODIUM CHLORIDE

Injection, USP

ADD-Vantage™ Diluent
Flexible Plastic Container

Rx only

DESCRIPTION

Sodium Chloride Injection, USP solutions are sterile and nonpyrogenic. They are parenteral solutions containing various concentrations of sodium chloride in water for injection intended for intravenous administration after admixing with an ADD-Vantage vial, or single-dose powdered drug vials with 20 mm closure using the ADD-Vantage ADDAPTOR™ (**WARNING: DO NOT USE WITH CHEMOTHERAPY AGENTS**).

Each 100 mL of 0.45% Sodium Chloride Injection, USP contains 450 mg sodium chloride in water for injection. Electrolytes per 1000 mL: sodium 77 mEq; chloride 77 mEq. The osmolarity is 154 mOsmol/L (calc.), which is hypotonic.

Each 100 mL of 0.9% Sodium Chloride Injection, USP contains 900 mg sodium chloride in water for injection. Electrolytes per 1000 mL: sodium 154 mEq; chloride 154 mEq. The osmolarity is 308 mOsmol/L (calc.), which is isotonic.

The pH for both concentrations is 5.6 (4.5 to 7.0).

The solutions contain no bacteriostat, antimicrobial agent or added buffer and each is intended only as a single-dose injection. When smaller doses are required the unused portion should be discarded.

The solutions are parenteral fluid and electrolyte replenishers.

Sodium Chloride, USP is chemically designated NaCl, a white crystalline powder freely soluble in water.

Water for Injection, USP is chemically designated H₂O.

The flexible plastic container is fabricated from a specially formulated polyvinylchloride. Water can permeate from inside the container into the overwrap but not in amounts sufficient to affect the solution significantly. Solutions in contact with the plastic container may leach out certain chemical components from the plastic in very small amounts; however, biological testing was supportive of the safety of the plastic container materials. Exposure to temperatures above 25°C/77°F during transport and storage will lead to minor losses in moisture content. Higher temperatures lead to greater losses. It is unlikely that these minor losses will lead to clinically significant changes within the expiration period.

CLINICAL PHARMACOLOGY

When administered intravenously, these solutions provide a source of water and electrolytes.

Solutions which provide an isotonic concentration of sodium chloride are suitable for parenteral maintenance or replacement of water and electrolyte requirements.

Isotonic concentrations of sodium chloride are suitable for parenteral replacement of chloride losses that exceed or equal the sodium loss. Sodium chloride in water dissociates to provide sodium (Na⁺) and chloride (Cl⁻) ions. Sodium (Na⁺) is the principal cation of the extracellular fluid and plays a large part in the therapy of fluid and electrolyte disturbances. Chloride (Cl⁻) has an integral role in buffering action when oxygen and carbon dioxide exchange occurs in the red blood cells. The distribution and

excretion of sodium (Na^+) and chloride (Cl^-) are largely under the control of the kidney which maintains a balance between intake and output.

Water is an essential constituent of all body tissues and accounts for approximately 70% of total body weight. Average normal adult daily requirements range from two to three liters (1.0 to 1.5 liters each for insensible water loss by perspiration and urine production).

Water balance is maintained by various regulatory mechanisms. Water distribution depends primarily on the concentration of electrolytes in the body compartments and sodium (Na^+) plays a major role in maintaining physiologic equilibrium.

INDICATIONS AND USAGE

Intravenous solutions containing sodium chloride are indicated for parenteral replenishment of fluid and sodium chloride as required by the clinical condition of the patient.

In this dosage form, Sodium Chloride Injection, USP is intended to be used as a diluent for the contents of an ADD-Vantage vial, or single-dose vials with 20 mm closure using the ADD-Vantage ADDAPTOR™.

CONTRAINDICATIONS

None known.

WARNINGS

Solutions containing sodium ions should be used with great care, if at all, in patients with congestive heart failure, severe renal insufficiency and in clinical states in which there exists edema with sodium retention.

Excessive administration of potassium-free solutions may result in significant hypokalemia.

In patients with diminished renal function, administration of solutions containing sodium ions may result in sodium retention.

The intravenous administration of these solutions can cause fluid and/or solute overloading resulting in dilution of serum electrolyte concentrations, overhydration, congested states or pulmonary edema.

The risk of dilutional states is inversely proportional to the electrolyte concentrations of administered parenteral solutions. The risk of solute overload causing congested states with peripheral and pulmonary edema is directly proportional to the electrolyte concentrations of such solutions.

PRECAUTIONS

General

Do not use plastic containers in series connections. Such use could result in air embolism due to residual air being drawn from the primary container before administration of the fluid from the secondary container is completed.

Use of a vented intravenous administration set with the vent in the open position could result in air embolism. Vented intravenous administration sets with the vent in the open position should not be used with flexible plastic containers.

Laboratory Tests

Clinical evaluation and periodic laboratory determinations are necessary to monitor changes in fluid balance, electrolyte concentrations and acid-base balance during prolonged parenteral therapy or whenever the condition of the patient warrants such evaluation.

DRUG INTERACTIONS

Caution must be exercised in the administration of parenteral fluids, especially those containing sodium ions to patients receiving corticosteroids or corticotropin.

Carcinogenesis, Mutagenesis, Impairment of Fertility: Studies with Sodium Chloride Injection, USP have not been performed to evaluate carcinogenic potential, mutagenic potential or effects on fertility.

Pregnancy: *Teratogenic effects*

Animal reproduction studies have not been conducted with Sodium Chloride Injection, USP. It is not known whether sodium chloride injection can cause fetal harm when administered to a pregnant woman or can affect reproduction capacity. Sodium Chloride Injection, USP should be given to a pregnant woman only if clearly needed.

Labor and Delivery: Studies have not been conducted to evaluate the effects of Sodium Chloride Injection, USP on labor and delivery. Caution should be exercised when administering this drug during labor and delivery.

Nursing Mothers: It is not known whether this drug is excreted in human milk. Because many drugs are excreted in human milk, caution should be exercised when Sodium Chloride Injection, USP is administered to a nursing mother.

Pediatric Use: Safety and effectiveness in children have not been established.

Geriatric Use: Clinical studies of Sodium Chloride Injection, USP did not include sufficient numbers of subjects aged 65 and over to determine whether they respond differently from younger subjects. Other reported clinical experience has not identified differences in responses between elderly and younger patients. In general, dose selection for an elderly patient should be cautious, usually starting at the low end of the dosing range, reflecting the greater frequency of decreased hepatic, renal, or cardiac function, and of concomitant disease or drug therapy.

This drug is known to be substantially excreted by the kidney, and the risk of toxic reactions to this drug may be greater in patients with impaired renal function. Because elderly patients are more likely to have decreased renal function, care should be taken in dose selection, and it may be useful to monitor renal function.

Do not administer unless solution is clear and container is undamaged. Discard unused portion.

ADVERSE REACTIONS

Reactions which may occur because of the solution or the technique of administration include febrile response, infection at the site of injection, venous thrombosis or phlebitis extending from the site of injection, extravasation and hypervolemia.

If an adverse reaction does occur, discontinue the infusion, evaluate the patient, institute appropriate therapeutic countermeasures and save the remainder of the fluid for examination if deemed necessary.

OVERDOSAGE

In the event of overhydration or solute overload, re-evaluate the patient and institute appropriate corrective measures. See **WARNINGS, PRECAUTIONS, and ADVERSE REACTIONS.**

DOSAGE AND ADMINISTRATION

The dose is dependent upon the age, weight and clinical condition of the patient.

Parenteral drug products should be inspected visually for particulate matter and discoloration prior to

administration, whenever solution and container permit. See **PRECAUTIONS**.

HOW SUPPLIED

Unit of Sale	Concentration	Each
NDC 0409-7132-66 Case of 50	0.45%	NDC 0409-7132-68 50 mL bags
NDC 0409-7132-67 Case of 50	0.45%	NDC 0409-7132-69 100 mL bags
NDC 0409-7132-02 Case of 24	0.45%	NDC 0409-7132-04 250 mL bags
NDC 0409-7101-66 Case of 50	0.9%	NDC 0409-7101-68 50 mL bags
NDC 0409-7101-67 Case of 50	0.9%	NDC 0409-7101-69 100 mL bags
NDC 0409-7101-02 Case of 24	0.9%	NDC 0409-7101-04 250 mL bags

Store at 20 to 25°C (68 to 77°F). [See USP Controlled Room Temperature.] Protect from freezing.

INSTRUCTIONS FOR USE WITH ADD-VANTAGE VIAL

These instructions for use should be made available to the individuals who perform the reconstitution steps.

To Open:

Peel overwrap at corner and remove solution container. Use unit within 30 days of opening overwrap, as long as the use date does not exceed the printed expiration date. Some opacity of the plastic due to moisture absorption during the sterilization process may be observed. This is normal and does not affect the solution quality or safety. The opacity will diminish gradually.

To Assemble Vial and Flexible Diluent Container:

(Use Aseptic Technique)

1. Remove the protective covers from the top of the vial and the vial port on the diluent container as follows:
 - a. To remove the breakaway vial cap, swing the pull ring over the top of the vial and pull down far enough to start the opening (SEE FIGURE 1), then pull straight up to remove the cap. (SEE FIGURE 2.)
NOTE: Once the breakaway cap has been removed, do not access vial with syringe.

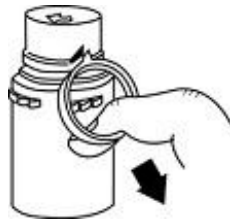

Fig. 1



Fig. 2

- b. To remove the vial port cover, grasp the tab on the pull ring, pull up to break the three tie strings, then pull back to remove the cover. (SEE FIGURE 3.)
2. Screw the vial into the vial port until it will go no further. **THE VIAL MUST BE SCREWED IN TIGHTLY TO ASSURE A SEAL.** This occurs approximately 1/2 turn (180°) after the first audible click. (SEE FIGURE 4.) The clicking sound does not assure a seal; the vial must be turned as far as it will go.

NOTE: Once vial is seated, do not attempt to remove. (SEE FIGURE 4.)
3. Recheck the vial to assure that it is tight by trying to turn it further in the direction of assembly.
4. Label appropriately.



Fig. 3

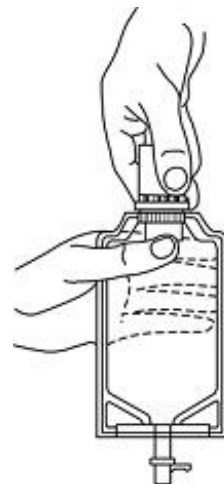

Fig. 4

To Reconstitute the Drug:

1. Squeeze the bottom of the diluent container gently to inflate the portion of the container surrounding the end of the drug vial.
2. With the other hand, push the drug vial down into the container telescoping the walls of the container. Grasp the inner cap of the vial through the walls of the container. (SEE FIGURE 5.)
3. **Pull the inner cap from the drug vial. (SEE FIGURE 6.) Verify that the rubber stopper has been pulled out, allowing the drug and diluent to mix.**
4. Mix container contents thoroughly and use within the specified time.

5. Look through the bottom of the vial to verify that the stopper has been removed and complete mixing has occurred. (SEE FIGURE 7.)

If the rubber stopper is not removed from the vial and medication is not released on the first attempt, the inner cap may be manipulated back into the rubber stopper without removing the drug vial from the diluent container. Repeat steps 3 through 5.

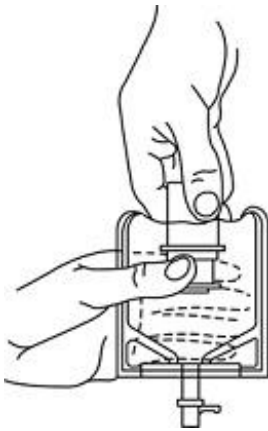

Fig. 5

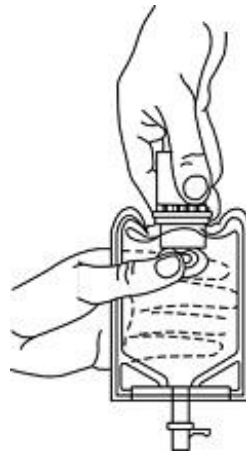

Fig. 6

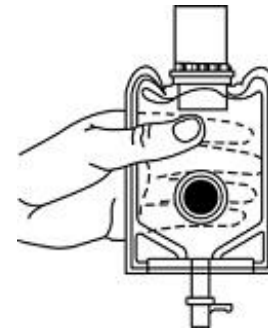

Fig.

7

Preparation for Administration:

(Use Aseptic Technique)

1. Confirm the activation and admixture of vial contents.
2. Check for leaks by squeezing container firmly. If leaks are found, discard unit as sterility may be impaired.
3. Close flow control clamp of administration set.
4. Remove cover from outlet port at bottom of container.
5. Insert piercing pin of administration set into port with a twisting motion until the pin is firmly seated. NOTE: See full directions on administration set carton.
6. Lift the free end of the hanger loop on the bottom of the vial, breaking the two tie strings. Bend the loop outward to lock it in the upright position, then suspend container from hanger.
7. Squeeze and release drip chamber to establish proper fluid level in chamber.
8. Open flow control clamp and clear air from set. Close clamp.
9. Attach set to venipuncture device. If device is not indwelling, prime and make venipuncture.
10. Regulate rate of administration with flow control clamp.

WARNING: Do not use flexible container in series connections.

INSTRUCTIONS FOR USE WITH ADD-VANTAGE ADDAPTOR™

The instructions for use provided with the ADD-Vantage ADDAPTOR™ should be made available to the individuals who perform the reconstitution steps.

Distributed by Hospira, Inc., Lake Forest, IL 60045 USA



Revised: 11/2018

PRINCIPAL DISPLAY PANEL - 50 mL Bag Label - NDC 0409-7101

PULL INNER PLUG/STOPPER
AND MIX DRUG BEFORE USE

ADD-Vantage™ Unit
NDC 0409-7101-68

0.9% SODIUM
CHLORIDE
Injection, USP

50
mL

EACH 100 mL CONTAINS SODIUM CHLORIDE 900 mg.
ELECTROLYTES (mEq/LITER): SODIUM 154 mEq; CHLORIDE
154 mEq. 308 mOsmol/LITER (calc.). pH 5.6 (4.5 TO 7.0)
FOR USE ONLY WITH ADD-Vantage™ SYSTEM COMPONENTS.
SINGLE-DOSE CONTAINER. FOR INTRAVENOUS USE. USUAL
DOSAGE: SEE PACKAGE INSERT. STERILE,
NONPYROGENIC. USE ONLY IF SOLUTION IS
CLEAR AND CONTAINER IS UNDEMANAGED. MUST
NOT BE USED IN SERIES CONNECTIONS. Rx ONLY

Hospira

3
v

CONTAINS DEHP

DISTRIBUTED BY
HOSPIRA, INC.,
LAKE FOREST, IL 60045 USA

IM-4474
14476101

**PULL INNER PLUG/STOPPER
AND MIX DRUG BEFORE USE**

NO COPY

MINIMUM CLEARANCE BETWEEN COLORS WHEN 2-COLOR PRINTING IS SPECIFIED

ADD-Vantage™ Unit NDC 0409-7101-68

**0.9% SODIUM
CHLORIDE** Injection, USP

**50
mL**

NO COPY
NO INK

EACH 100 mL CONTAINS SODIUM CHLORIDE 900 mg.
ELECTROLYTES (mEq/LITER): SODIUM 154 mEq; CHLORIDE
154 mEq. 308 mOsmol/LITER (calc.). pH 5.6 (4.5 TO 7.0)
FOR USE ONLY WITH ADD-Vantage™ SYSTEM COMPONENTS.
SINGLE-DOSE CONTAINER. FOR INTRAVENOUS USE. USUAL
DOSAGE: SEE PACKAGE INSERT. STERILE,
NONPYROGENIC. USE ONLY IF SOLUTION IS
CLEAR AND CONTAINER IS UNDAMAGED. MUST
NOT BE USED IN SERIES CONNECTIONS. Rx ONLY



CONTAINS DEHP

DISTRIBUTED BY
HOSPIRA, INC. IM-4474
LAKE FOREST, IL 60045 USA 14476101

EXP
LOT

HOT STAMP LOT NO.
AND EXP. DATE
TARGET AREA

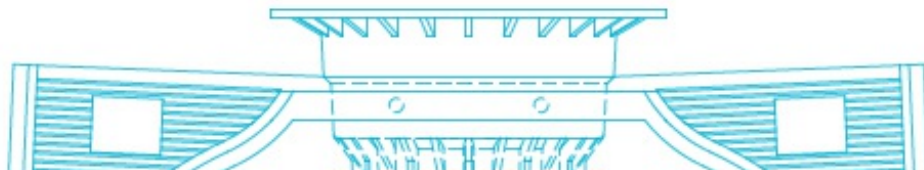
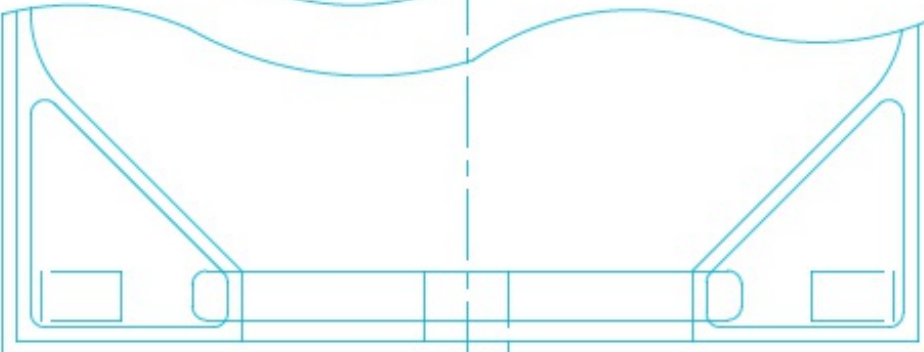

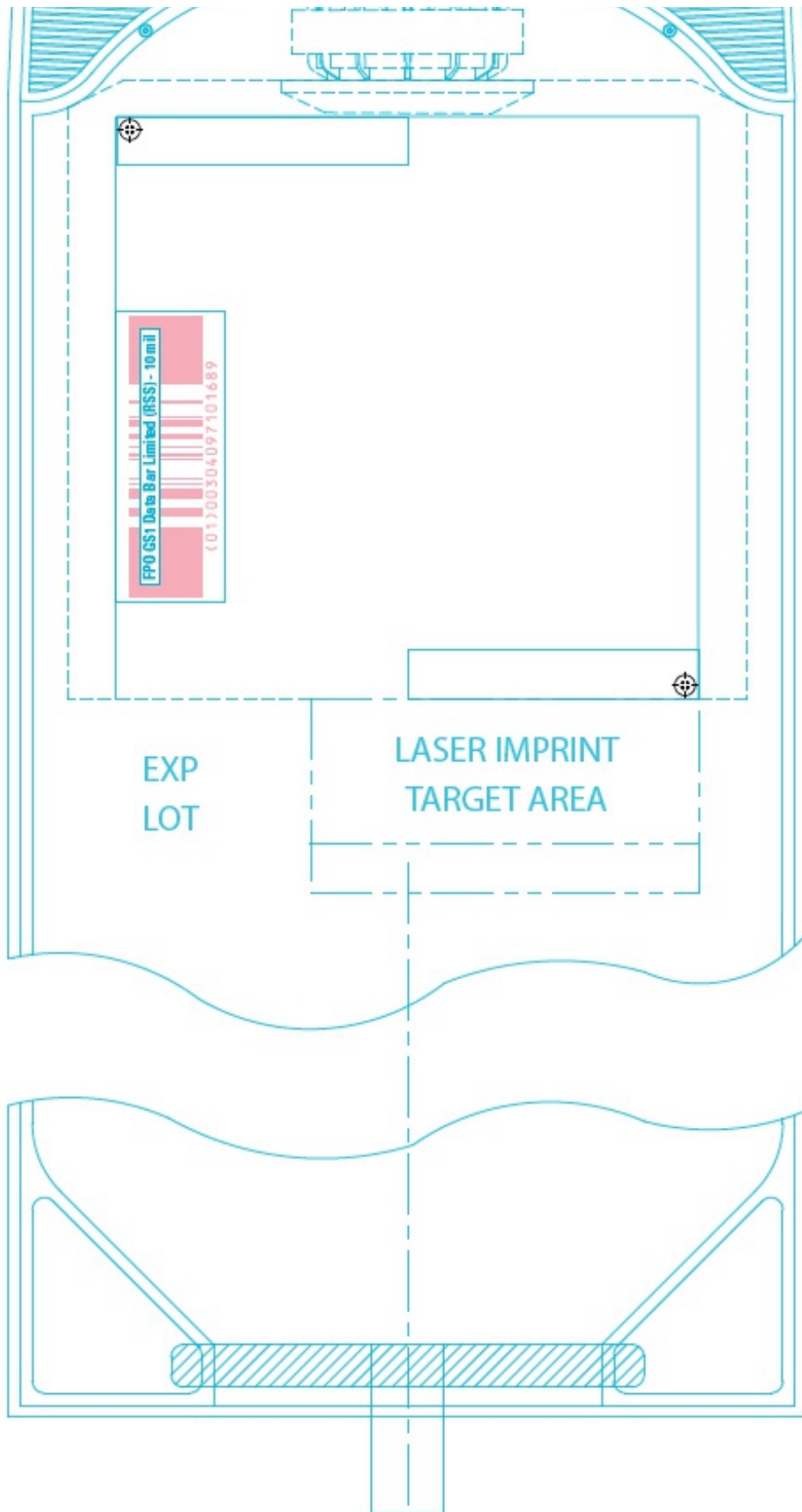

PRINCIPAL DISPLAY PANEL - 100 mL Bag Label - NDC 0409-7101

PULL INNER PLUG/STOPPER
AND MIX DRUG BEFORE USE

ADD-Vantage™ Unit
NDC 0409-7101-69

0.9% SODIUM
CHLORIDE
Injection, USP

100
mL

EACH 100 mL CONTAINS SODIUM CHLORIDE 900 mg.
ELECTROLYTES (mEq/LITER): SODIUM 154 mEq; CHLORIDE
154 mEq. 308 mOsmol/LITER (calc.). pH 5.6 (4.5 TO 7.0)
FOR USE ONLY WITH ADD-Vantage™ SYSTEM COMPONENTS.
SINGLE-DOSE CONTAINER. FOR INTRAVENOUS USE. USUAL
DOSAGE: SEE PACKAGE INSERT. STERILE,
NONPYROGENIC. USE ONLY IF SOLUTION IS
CLEAR AND CONTAINER IS UNDAMAGED. MUST
NOT BE USED IN SERIES CONNECTIONS. Rx ONLY

Hospira

3
v

CONTAINS DEHP

DISTRIBUTED BY
HOSPIRA, INC.,
LAKE FOREST, IL 60045 USA

IM-4475
14476401

**PULL INNER PLUG/STOPPER
AND MIX DRUG BEFORE USE**

NO COPY

MINIMUM CLEARANCE BETWEEN COLORS WHEN 2-COLOR PRINTING IS SPECIFIED

ADD-Vantage™ Unit NDC 0409-7101-69

NO COPY
NO INK

**0.9% SODIUM
CHLORIDE**

Injection, USP

**100
mL**

EACH 100 mL CONTAINS SODIUM CHLORIDE 900 mg,¹
ELECTROLYTES (mEq/LITER): SODIUM 154 mEq; CHLORIDE
154 mEq. 308 mOsmol/LITER (calc.). pH 5.6 (4.5 TO 7.0)
FOR USE ONLY WITH ADD-Vantage™ SYSTEM COMPONENTS.
SINGLE-DOSE CONTAINER. FOR INTRAVENOUS USE. USUAL
DOSAGE: SEE PACKAGE INSERT. STERILE,
NONPYROGENIC. USE ONLY IF SOLUTION IS
CLEAR AND CONTAINER IS UNDEFORMED. MUST
NOT BE USED IN SERIES CONNECTIONS. Rx ONLY



CONTAINS DEHP

DISTRIBUTED BY

HOSPIRA, INC.,
LAKE FOREST, IL 60045 USA

IM-4475
14476401

EXP
LOT

HOT STAMP LOT NO.
AND EXP. DATE
TARGET AREA

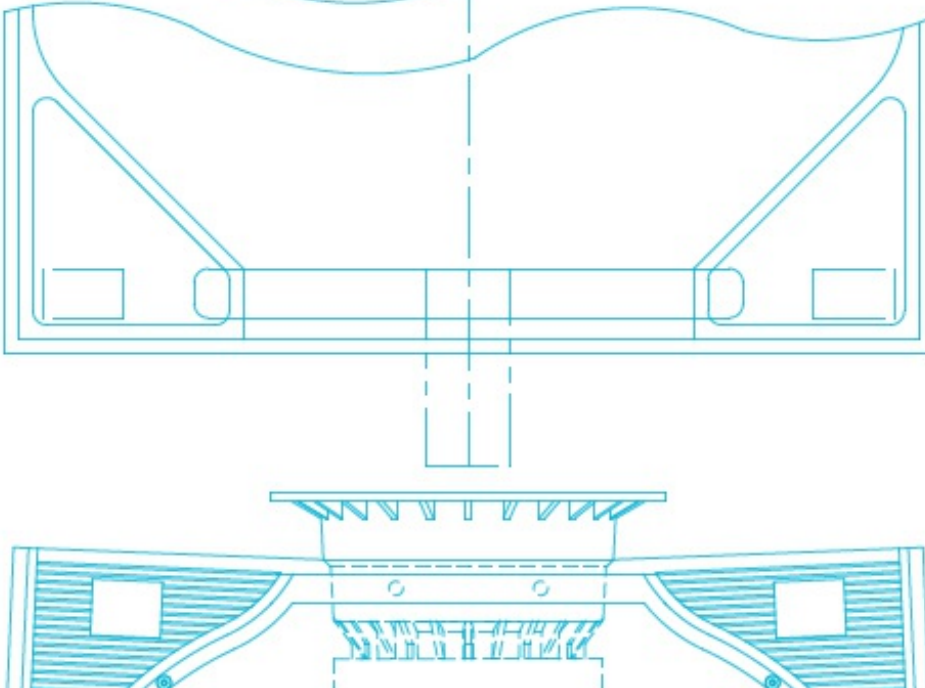

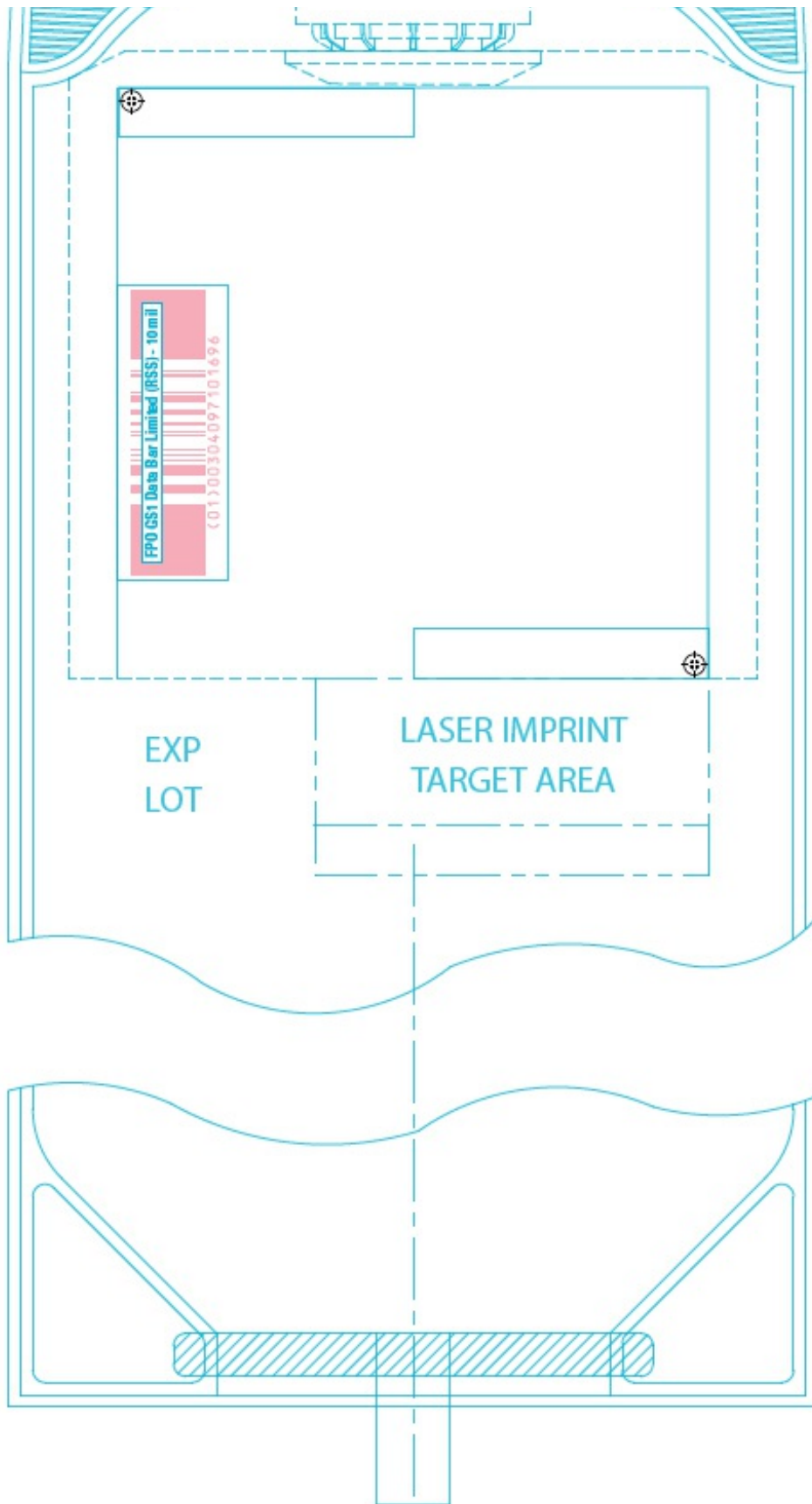

PRINCIPAL DISPLAY PANEL - 50 ML AND 100 ML BAG OVERWRAP LABEL – NDC 0409-7101

TO OPEN – PEEL AT NOTCH

Five/ADD-Vantage™ Units

For use only with ADD-Vantage™ system components.

The overwrap is a moisture barrier. Use units within 30 days of opening overwrap, as long as the use date does not exceed the printed expiration date. After removing the overwrap, check for minute leaks by squeezing container firmly. If leaks are found, discard unit as sterility may be impaired. Store at 20 to 25°C (68 to 77°F). [See USP Controlled Room Temperature.]

Rx only

14475301

Distributed by Hospira, Inc., Lake Forest, IL 60045 USA

Hospira

WR-0581

TO OPEN – PEEL AT NOTCH
Five/ADD-Vantage™ Units

For use only with ADD-Vantage™ system components.

The overwrap is a moisture barrier. Use units within 30 days of opening overwrap, as long as the use date does not exceed the printed expiration date. After removing the overwrap, check for minute leaks by squeezing container firmly. If leaks are found, discard unit as sterility may be impaired. Store at 20 to 25°C (68 to 77°F). [See USP Controlled Room Temperature.]

Rx only

14475301

Distributed by Hospira, Inc., Lake Forest, IL 60045 USA



WR-0581

PRINCIPAL DISPLAY PANEL - 250 mL Bag Label - NDC 0409-7101

LOT

EXP.

PULL INNER PLUG/STOPPER
AND MIX DRUG BEFORE USE

ADD-Vantage™ Unit

NDC 0409-7101-04

0.9%

SODIUM CHLORIDE

Injection, USP

250

mL

EACH 100 mL CONTAINS

SODIUM CHLORIDE 900 mg.

ELECTROLYTES (mEq/LITER):

SODIUM 154 mEq; CHLORIDE

154 mEq. 308 mOsmol/LITER

(calc). pH 5.6 (4.5 TO 7.0).
FOR USE ONLY WITH
ADD-Vantage™ SYSTEM
COMPONENTS. SINGLE-
DOSE CONTAINER. FOR
INTRAVENOUS USE. USUAL
DOSAGE: SEE INSERT.
STERILE, NONPYROGENIC.
USE ONLY IF SOLUTION IS
CLEAR AND CONTAINER IS
UNDAMAGED. MUST NOT
BE USED IN SERIES
CONNECTIONS.
Rx ONLY

DISTRIBUTED BY HOSPIRA, INC.,
LAKE FOREST, IL 60045 USA

Hospira

3

v

CONTAINS DEHP

IM-4476

14476601

LOT



EXP

**PULL INNER PLUG/STOPPER
AND MIX DRUG BEFORE USE**

ADD-Vantage™ Unit

NDC 0409-7101-04

0.9%
SODIUM CHLORIDE
Injection, USP

250
mL

NO COPY, NO INK

EACH 100 mL CONTAINS
SODIUM CHLORIDE 900 mg.
ELECTROLYTES (mEq/LITER):
SODIUM 154 mEq; CHLORIDE
154 mEq. 308 mOsmol/LITER
(calc). pH 5.6 (4.5 TO 7.0).

FOR USE ONLY WITH
ADD-Vantage™ SYSTEM
COMPONENTS. SINGLE-
DOSE CONTAINER. FOR
INTRAVENOUS USE. USUAL
DOSAGE: SEE INSERT.
STERILE, NONPYROGENIC.
USE ONLY IF SOLUTION IS
CLEAR AND CONTAINER IS
UNDAMAGED. MUST NOT
BE USED IN SERIES
CONNECTIONS. Rx ONLY

DISTRIBUTED BY HOSPIRA, INC.,
LAKE FOREST, IL 60045 USA



CONTAINS DEHP

IM-4476
14476601



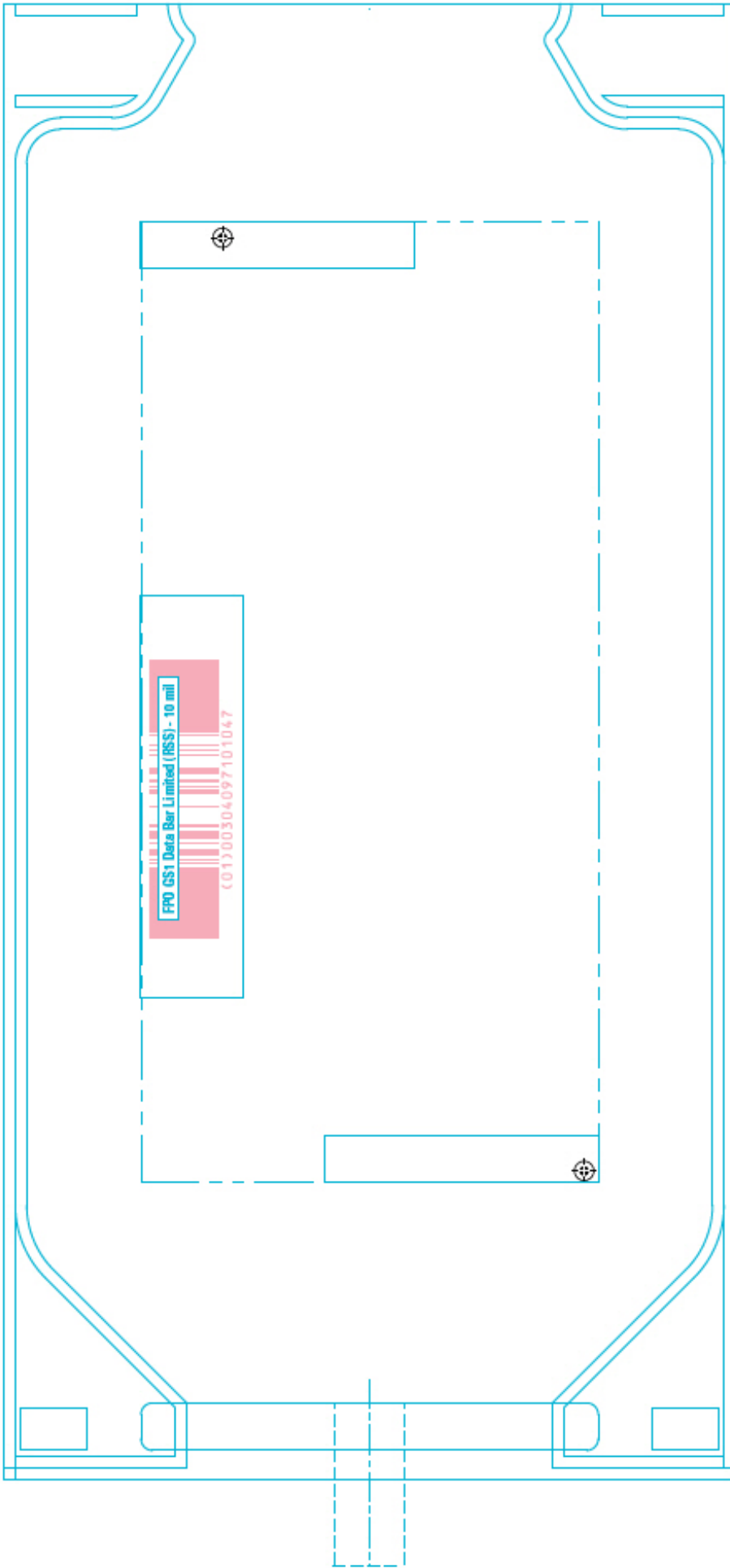

PRINCIPAL DISPLAY PANEL - 250 mL Bag Overwrap Label - NDC 0409-7101

One/ADD-Vantage™ Unit
TO OPEN–PEEL AT CORNER

For use only with ADD-Vantage™ system components.

The overwrap is a moisture barrier. Use unit within 30 days of opening overwrap, as long as the use date does not exceed the printed expiration date. Store at 20 to 25°C (68 to 77°F). [See USP Controlled Room Temperature.] Protect from freezing. See insert. After removing the overwrap, check for minute leaks by squeezing container firmly. If leaks are found, discard unit as sterility may be impaired.

Rx only

14475901

Distributed by Hospira, Inc., Lake Forest, IL 60045 USA

Hospira

WR-0583

**One/ADD-Vantage™ Unit
TO OPEN–PEEL AT CORNER**

For use only with ADD-Vantage™ system components.

The overwrap is a moisture barrier. Use unit within 30 days of opening overwrap, as long as the use date does not exceed the printed expiration date. Store at 20 to 25°C (68 to 77°F). [See USP Controlled Room Temperature.] Protect from freezing. See insert. After removing the overwrap, check for minute leaks by squeezing container firmly. If leaks are found, discard unit as sterility may be impaired.

Rx only

14475901

Distributed by Hospira, Inc., Lake Forest, IL 60045 USA



WR-0583

PRINCIPAL DISPLAY PANEL - 50 mL Bag Label - NDC 0409-7132

**PULL INNER PLUG/STOPPER
AND MIX DRUG BEFORE USE**

ADD-Vantage™ Unit
NDC 0409-7132-68

**0.45% SODIUM
CHLORIDE Injection, USP**

**50
mL**

EACH 100 mL CONTAINS SODIUM CHLORIDE
450 mg. ELECTROLYTES (mEq/LITER): SODIUM
77 mEq; CHLORIDE 77 mEq. 154 mOsmol/LITER
(calc.). pH 5.6 (4.5 TO 7.0) FOR USE ONLY WITH
ADD-Vantage™ SYSTEM COMPONENTS. SINGLE-
DOSE CONTAINER. FOR I.V. USE. USUAL DOSAGE: SEE
PACKAGE INSERT. STERILE, NONPYROGENIC. USE
ONLY IF SOLUTION IS CLEAR AND
CONTAINER IS UNDAMAGED.
MUST NOT BE USED IN SERIES CONNECTIONS.

**3
v**
CONTAINS DEHP

Rx ONLY

IM-3519

HOSPIRA, INC., LAKE FOREST, IL 60045 USA

**PULL INNER PLUG/STOPPER
AND MIX DRUG BEFORE USE**

ADD-Vantage™ Unit

NDC 0409-7132-68

**0.45% SODIUM
CHLORIDE** Injection, USP

**50
mL**

EACH 100 mL CONTAINS SODIUM CHLORIDE 450 mg. ELECTROLYTES (mEq/LITER): SODIUM 77 mEq; CHLORIDE 77 mEq. 154 mOsmol/LITER (calc.). pH 5.6 (4.5 TO 7.0) FOR USE ONLY WITH ADD-Vantage™ SYSTEM COMPONENTS. SINGLE-DOSE CONTAINER. FOR I.V. USE. USUAL DOSAGE: SEE PACKAGE INSERT. STERILE, NONPYROGENIC. USE ONLY IF SOLUTION IS CLEAR AND CONTAINER IS UNDAMAGED.

MUST NOT BE USED IN SERIES CONNECTIONS.
Rx ONLY



IM-3519

CONTAINS DEHP

HOSPIRA, INC., LAKE FOREST, IL 60045 USA

PRINCIPAL DISPLAY PANEL - 50 mL Bag Overwrap Label - NDC 0409-7132

TO OPEN – PEEL AT NOTCH

Five/ADD-Vantage™ Units

For use only with ADD-Vantage™ system components.

The overwrap is a moisture barrier. Use units within 30 days of opening overwrap, as long as the use date does not exceed the printed expiration date. After removing the overwrap, check for minute leaks by squeezing container firmly. If leaks are found, discard unit as sterility may be impaired. Store at 20 to 25°C (68 to 77°F). [See USP Controlled Room Temperature.]

Rx only

14475301

Distributed by Hospira, Inc., Lake Forest, IL 60045 USA

Hospira

WR-0581

TO OPEN – PEEL AT NOTCH
Five/ADD-Vantage™ Units

For use only with ADD-Vantage™ system components.

The overwrap is a moisture barrier. Use units within 30 days of opening overwrap, as long as the use date does not exceed the printed expiration date. After removing the overwrap, check for minute leaks by squeezing container firmly. If leaks are found, discard unit as sterility may be impaired. Store at 20 to 25°C (68 to 77°F). [See USP Controlled Room Temperature.]

Rx only

14475301

Distributed by Hospira, Inc., Lake Forest, IL 60045 USA



WR-0581

PRINCIPAL DISPLAY PANEL - 250 mL Bag Label - NDC 0409-7132

LOT
EXP.

**PULL INNER PLUG/STOPPER
AND MIX DRUG BEFORE USE**

ADD-Vantage™ Unit
NDC 0409-7132-04

0.45%
SODIUM CHLORIDE
Injection, USP

250
mL

EACH 100 mL CONTAINS
SODIUM CHLORIDE 450 mg.
ELECTROLYTES (mEq/LITER):
SODIUM 77 mEq; CHLORIDE
77 mEq. 154 mOsmol/LITER
(calc). pH 5.6 (4.5 TO 7.0). FOR
USE ONLY WITH ADD-Vantage™
SYSTEM COMPONENTS.
SINGLE-DOSE CONTAINER. FOR
INTRAVENOUS USE. USUAL
DOSAGE: SEE INSERT. STERILE,
NONPYROGENIC. USE ONLY
IF SOLUTION IS CLEAR AND
CONTAINER IS UNDAMAGED.
MUST NOT BE USED IN SERIES
CONNECTIONS.

Rx ONLY

3
v

CONTAINS DEHP

IM-3521

HOSPIRA, INC., LAKE FOREST, IL 60045 USA

Hospira

LOT ↑ EXP.

PULL INNER PLUG/STOPPER
AND MIX DRUG BEFORE USE

ADD-Vantage™ Unit NDC 0409-7132-04

0.45%

SODIUM CHLORIDE

250
mL

Injection, USP

EACH 100 mL CONTAINS	0
SODIUM CHLORIDE 450 mg.	
ELECTROLYTES (mEq/LITER):	
SODIUM 77 mEq; CHLORIDE	50
77 mEq. 154 mOsmo/LITER	
(calc). pH 5.6 (4.5 TO 7.0). FOR	
USE ONLY WITH ADD-Vantage™	100
SYSTEM COMPONENTS.	
SINGLE-DOSE CONTAINER. FOR	
INTRAVENOUS USE. USUAL	
DOSAGE: SEE INSERT. STERILE,	
NONPYROGENIC. USE ONLY	150
IF SOLUTION IS CLEAR AND	
CONTAINER IS UNDAMAGED.	
MUST NOT BE USED IN SERIES	
CONNECTIONS.	

10170034097132041

Rx ONLY  

CONTAINS DEHP

IM-3521

HOSPIRA, INC., LAKE FOREST, IL 60045 USA

200

PRINCIPAL DISPLAY PANEL - 250 mL Bag Overwrap Label - NDC 0409-7132

One/ADD-Vantage™ Unit

TO OPEN-PEEL AT CORNER

For use only with ADD-Vantage™ system components.

The overwrap is a moisture barrier. Use unit within 30 days of opening

overwrap, as long as the use date does not exceed the printed expiration date. Store at 20 to 25°C (68 to 77°F). [See USP Controlled Room Temperature.] Protect from freezing. See insert. After removing the overwrap, check for minute leaks by squeezing container firmly. If leaks are found, discard unit as sterility may be impaired.

Rx only

14475901

Distributed by Hospira, Inc., Lake Forest, IL 60045 USA

Hospira

WR-0583

One/ADD-Vantage™ Unit TO OPEN—PEEL AT CORNER

For use only with ADD-Vantage™ system components.

The overwrap is a moisture barrier. Use unit within 30 days of opening overwrap, as long as the use date does not exceed the printed expiration date. Store at 20 to 25°C (68 to 77°F). [See USP Controlled Room Temperature.] Protect from freezing. See insert. After removing the overwrap, check for minute leaks by squeezing container firmly. If leaks are found, discard unit as sterility may be impaired.



Rx only

14475901

Distributed by Hospira, Inc., Lake Forest, IL 60045 USA

WR-0583

SODIUM CHLORIDE

sodium chloride injection, solution

Product Information

Product Type	HUMAN PRESCRIPTION DRUG	Item Code (Source)	NDC:0409-7101
Route of Administration	INTRAVENOUS		

Active Ingredient/Active Moiety

Ingredient Name	Basis of Strength	Strength
SODIUM CHLORIDE (UNII: 451W47IQ8X) (SODIUM CATION - UNII:L4YR4M0NH37, CHLORIDE ION - UNII:Q32ZN48698)	SODIUM CHLORIDE	900 mg in 100 mL

Inactive Ingredients

Ingredient Name	Strength
WATER (UNII: 059QF0KO0R)	

Packaging

#	Item Code	Package Description	Marketing Start Date	Marketing End Date
1	NDC:0409-7101-66	10 in 1 CASE	07/19/2005	
1		5 in 1 POUCH		
1	NDC:0409-7101-68	50 mL in 1 BAG; Type 0: Not a Combination Product		
2	NDC:0409-7101-67	10 in 1 CASE	08/24/2005	
2		5 in 1 POUCH		
2	NDC:0409-7101-69	100 mL in 1 BAG; Type 0: Not a Combination Product		
3	NDC:0409-7101-02	24 in 1 CASE	06/30/2005	
3		1 in 1 POUCH		
3	NDC:0409-7101-04	250 mL in 1 BAG; Type 0: Not a Combination Product		

Marketing Information

Marketing Category	Application Number or Monograph Citation	Marketing Start Date	Marketing End Date
NDA	NDA019465	06/30/2005	

SODIUM CHLORIDE

sodium chloride injection, solution

Product Information

Product Type	HUMAN PRESCRIPTION DRUG	Item Code (Source)	NDC:0409-7132
Route of Administration	INTRAVENOUS		

Active Ingredient/Active Moiety

Ingredient Name	Basis of Strength	Strength
SODIUM CHLORIDE (UNII: 451W47IQ8X) (SODIUM CATION - UNII:LYR4M0NH37, CHLORIDE ION - UNII:Q32ZN48698)	SODIUM CHLORIDE	450 mg in 100 mL

Inactive Ingredients

Ingredient Name	Strength
WATER (UNII: 059QF0KO0R)	

Packaging

#	Item Code	Package Description	Marketing Start Date	Marketing End Date
---	-----------	---------------------	----------------------	--------------------

1	NDC:0409-7132-66	10 in 1 CASE	09/13/2005	11/01/2019
1		5 in 1 POUCH		
1	NDC:0409-7132-68	50 mL in 1 BAG; Type 0: Not a Combination Product		
2	NDC:0409-7132-67	10 in 1 CASE	11/15/2005	10/01/2019
2		5 in 1 POUCH		
2	NDC:0409-7132-69	100 mL in 1 BAG; Type 0: Not a Combination Product		
3	NDC:0409-7132-02	24 in 1 CASE	05/25/2006	03/01/2020
3		1 in 1 POUCH		
3	NDC:0409-7132-04	250 mL in 1 BAG; Type 0: Not a Combination Product		

Marketing Information

Marketing Category	Application Number or Monograph Citation	Marketing Start Date	Marketing End Date
NDA	NDA019759	09/13/2005	03/01/2020

Labeler - Hospira, Inc. (141588017)

Establishment

Name	Address	ID/FEI	Business Operations
Hospira, Inc.		827731089	ANALYSIS(0409-7101, 0409-7132)

Revised: 10/2020

Hospira, Inc.